

General Twin Seal™

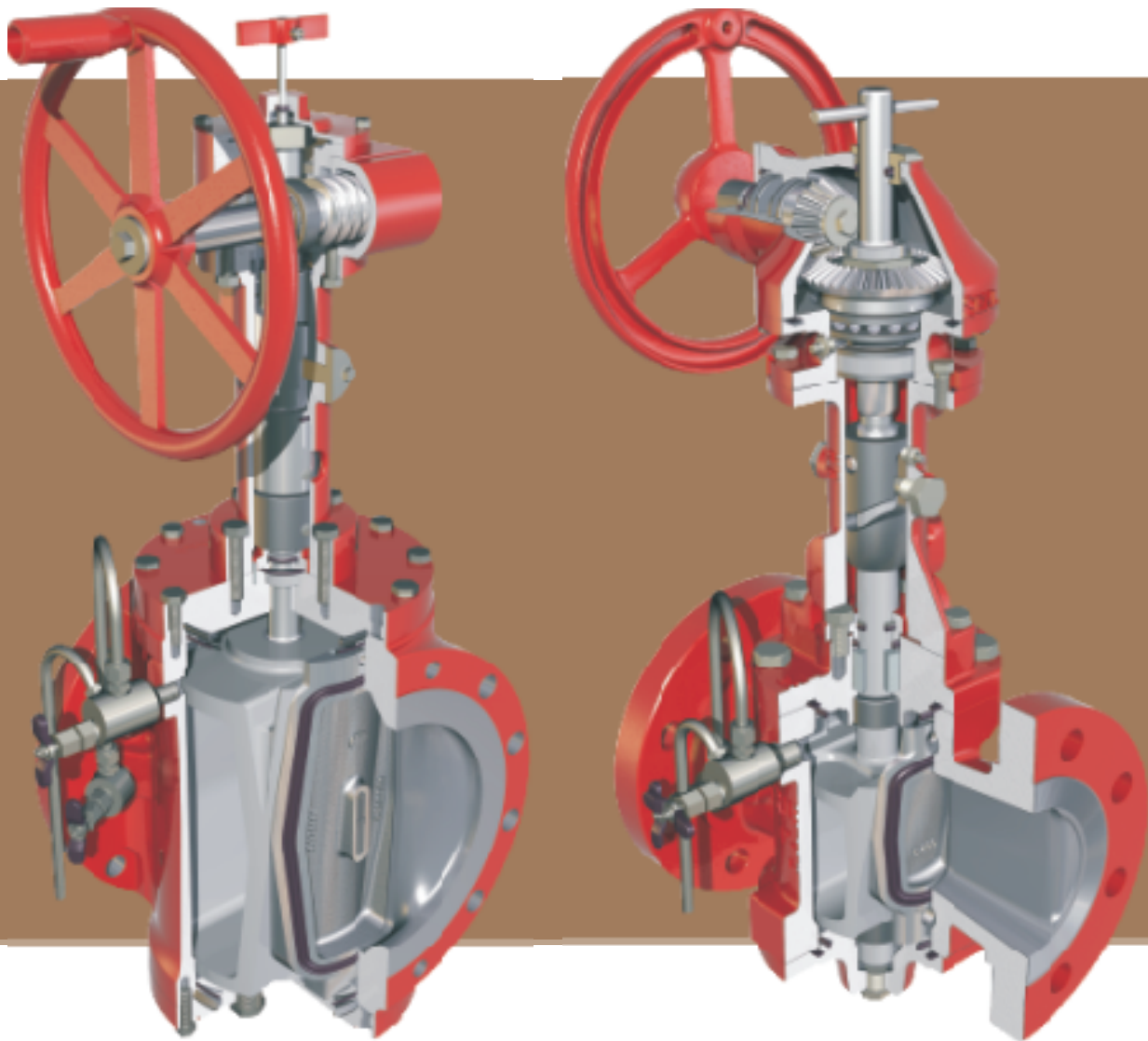

GENERAL VALVE®

TABLE OF CONTENTS

GENERAL TWIN SEAL

Features and Benefits _____ 1, 2, 3 & 4

DIMENSION TABLES

General TruSeal 200 _____ 5

General Twin Seal 8800 _____ 6

General Twin Seal 800 _____ 7

General Twin Seal 400 _____ 8

General twin Seal 900 _____ 9

GENERAL TWIN SEAL

SEAT & RESEAT _____ 10

General Seat & Reseat 1600 _____ 11

General Seat & Reseat 1500 _____ 12

ELECTRIC ACTUATORS _____ 13

PNEUMATIC ACTUATORS _____ 14

LIMIT SWITCHES _____ 15

MECHANICAL EXTENSIONS _____ 15

DIRECT BURIAL - UNDERGROUND _____ 16

PRESSURE RELIEF SYSTEMS _____ 17 & 18

STANDARD MATERIALS _____ 19

TRADEMARK INFORMATION _____ 20

TERMS AND CONDITIONS _____ 21

GENERAL TWIN SEAL

THE EVOLUTION OF DOUBLE BLOCK & BLEED CONTINUES . . .

Cameron is the world's leading manufacturer of high-integrity, positive shutoff Double Block & Bleed valves which serve the following markets: pipeline, liquid bulk terminals, aviation fueling, refining, oil/gas production and custody transfer for the petroleum and oil and gas industries.

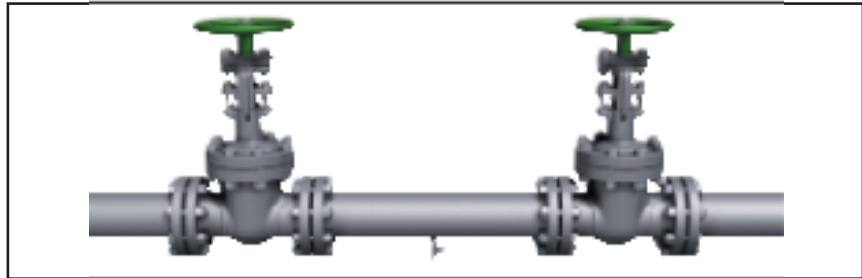

The age-old "Double Block & Bleed" system (as shown above) required the use of two valves and a spool piece. A bleed valve was used to drain the spool and verify seal integrity.



Tank Farm



Marine Loading

Introduced in 1941, General Twin Seal valves, were the first to meet the rigid requirements of Double Block & Bleed service - more than 65 years ago. In the years since, subtle yet significant design refinements have been made to improve the valve's performance. Superior design innovations, pride in manufacturing workmanship and the selection of the best materials, support Cameron' commitment to excellence and complete customer satisfaction.



The General Twin Seal replaces this antiquated two-valve system with just one double seated bubble-tight valve.

The upstream and downstream seals provide the same function as the two block valves. The body (serving as a spool piece) bleed verifies seal integrity.

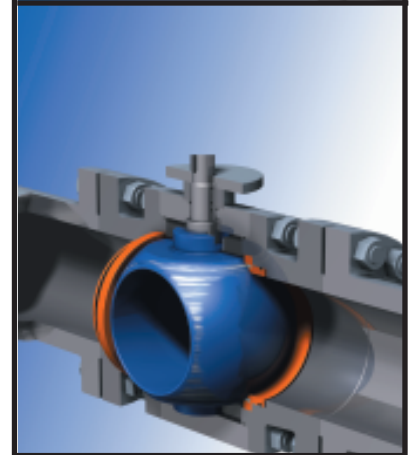
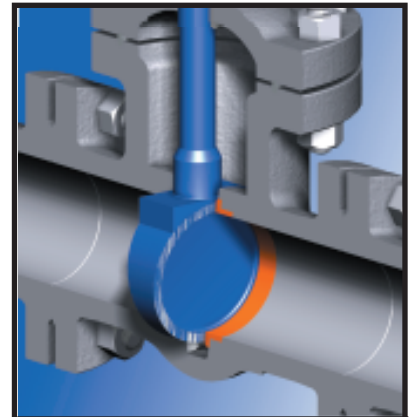

Scored seating segments

Seal abrasion is inherent in the design of most ball and gate valves. In most instances, the seats are ground or wedged against metal every time the valve cycles. Any foreign material lodged between the seats and ball or gate will score the seating surfaces. Once the seating segment is scored, product loss and contamination results. The General Twin Seal avoids abrasion by having both independent slips totally retracted from the body bore during cycling.

General Twin Seal's totally retracted slip design eliminates wear, minimizes leakage risk, reduces maintenance and saves money.

GENERAL TWIN SEAL

THE PROVABLE ZERO-LEAKAGE DOUBLE BLOCK AND BLEED PLUG VALVE WITH RETRACTING SEALS



Contamination is Avoided in Multi-Products manifolds

Multi-Product Manifolds

The General Twin Seal positive shut-off, Double Block and Bleed valve was developed for multi-products fuel manifolds.

Busy manifolds must be operated frequently, switching from product to product, often with power actuators and sometimes without human supervision. Valves that can be trusted to seal drop-tight, every time, will prevent the expensive consequences of contaminated fuel.

Liquid fuels that move through pipeline manifolds are reliably segregated by provable, zero-leakage, General Twin Seal valves.

Every General Twin Seal valve in the manifold has assured Double Block and Bleed shut-off that proves total isolation of each product.

By using General Twin Seal valves, gasoline, diesel, kerosene, jet fuel, heating oil and LPG as well as crude oil and natural gas are **protected from contamination.**



Meter Block Valves Hold the Key to Accurate Measurements

Meter Stations

Flow meters require calibration to verify their accuracy. During meter calibration (proving), every closed valve in the meter system must seal drop tight. Even a small leak will cause errors in the meter calibration.

The incorrect meter factor will persist until the next proving operation and incorrect flow measurement can cost huge sums of money!

Every General Twin Seal valve in the meter station can be quickly and easily shown to be holding leak-tight. That means **correct calibration...every time.**

Problems With Other Valves

In meter block service, the differential pressure across each closed valve is very low. There is no assistance required from the line pressure to "energize" or compress floating seals to make them hold tight. Unless the body cavity in a ball valve is vented, the seals typically rely on springs to press them against the ball. The ball valve may be leaking until the user opens the bleed. Then the reduction of the body pressure introduces a hydraulic force on the seat that may stop the leak. The user can form a false impression that the ball valve is holding tight, when in reality, it leaks.

In contrast, the mechanical wedge-action of the General Twin Seal plug compresses both the upstream and the downstream seals firmly against the valve body, needing no help from the line pressure. **General Twin Seal valves hold with consistent zero-leakage.**

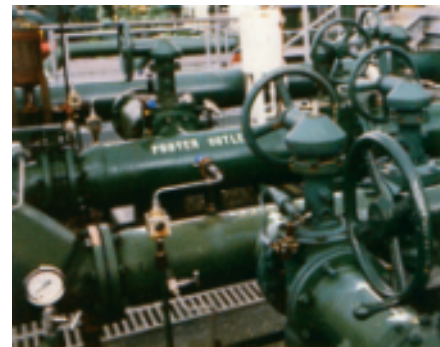

General Twin Seal Valves Work in Meter Systems... Ordinary Valves Don't!

GENERAL TWIN SEAL

Tank Storage Isolation

Fuel in storage tanks is exposed to the risk of contamination and loss of volume unless the tank isolation valves can be checked for zero leakage. Tank side valves are operated frequently, but assuring tank integrity without General Twin Seal can be troublesome and expensive. Using line blinds (or “skillet plates”) for segregation involves a long, costly and perhaps hazardous operation of drain-down, lock-out and tag-out. Traditional gate valve Double Block & Bleed will produce constant loss of fuel from the open bleed. General Twin Seal valves offer simple, provable, tank-side isolation. There is absolute assurance of valve integrity.



Tank-Side Isolation Maintains Product Integrity

Hydrant Isolation

Fuel hydrants at busy airports must be regularly pressure tested to check the integrity of the pipes, flanges and gaskets. But the only time this inspection can be performed is in the few hours each night when the airport is closed. On some occasions, sections of the hydrant must be isolated for extension, modification or repair. Or, it may become necessary to isolate, section by section, to find the location of a leak. Airports don't have the time to drain fuel from the lines or to swing line blinds for traditional line block, but the entire hydrant must be isolated and pressurized to prove that it is safe.



Buried Hydrants Require Regular Pressure Tests

General Twin Seal valves are the recognized Hydrant Valves for airport service because:

- They close quickly and easily.
- They require very little maintenance.
- They hold with zero-leakage.

The hydrant pressure-test can begin as soon as the valves are closed, since the General Twin Seal valves ensure that the hydrant is totally isolated.

Loading / Unloading

Fuel loading/unloading may require hundreds of open/close strokes of the connection valves every day. The valves typically operate against full pump pressure on every stroke, and they must close without leakage. Safety and environmental concerns demand that the fuel is absolutely and totally contained within the pipe, yet the valves must operate quickly and easily. General Twin Seal valves have two resilient seals that fully retract from their seated position without any seal rubbing...even at full differential pressure. Plug turning is effortless AND slam-proof!



Fuel loading hazards are eliminated

Countless loading facilities depend on General Twin Seal valves for safe, reliable, zero-leakage shut-off at rail, truck and shipload manifolds. From Alaska to Argentina; from Sidney to Sicily; from New York to New Zealand, fuel movement managers have discovered General Twin Seal valves are the only valves they can trust to deliver real dependability at their loading manifolds.

GENERAL TWIN SEAL

HOW THE GENERAL TWIN SEAL WORKS

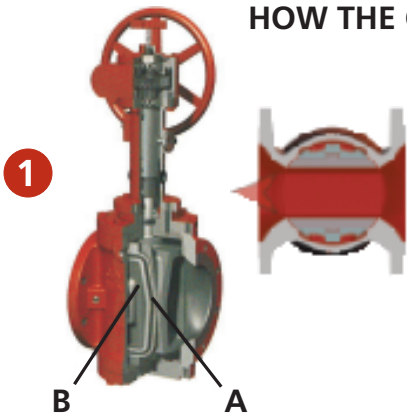

The internal design is very simple. Seals (A) are permanently bonded into the slips (B) which are mounted on a central plug. In the open position the slip seals are completely out of the flow.

Simple, in-line field maintenance keeps costs down

A big advantage of General Twin Seal's design is that it permits "in-line" servicing. By simply removing the valve bonnet or lower plate (after the line is depressurized and drained), all models may be repaired from top or bottom without removing the valve from the line.



Turning the operator handwheel clockwise rotates the plug assembly 90° to block flow. During rotation, clearance is maintained between the seal and the valve body, allowing free movement and avoiding abrasion.

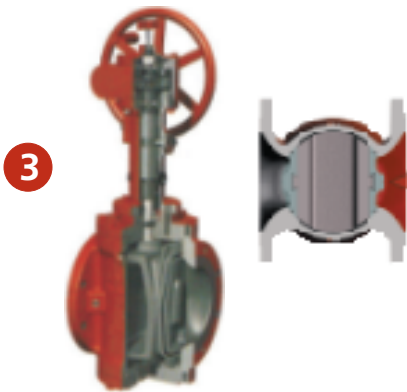

When the operator is turned further clockwise, the tapered plug begins to lower, forcing the slips against the body initiating the verifiable seal. Because the seals never drag, the valve requires less torque to cycle.

WARNING: Do not attempt any repairs on General Twin Seal valves unless you are certain the line pressure has been removed and the line contents drained from the valve and the line and the body cavity! Failure to follow these instructions could result in injury to personnel, or cause hazardous product to be vented from the valve. For complete instructions on installation and repair, request a copy of **General Twin Seal Installation Manual** from your local Cameron Sales Office.

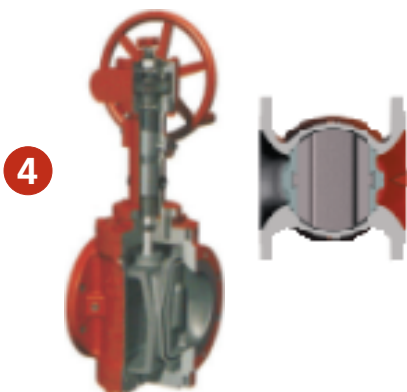

In the closed position, the slip seals are expanded, compressing the slip seals until metal-to-metal seating is effected. Because it is mechanical, the Twin Seal doesn't rely on line pressure differential to help make its seal. It even seals in vacuum service.

GENERAL TRUSEAL 200

Handwheel Operated

Gear Operated

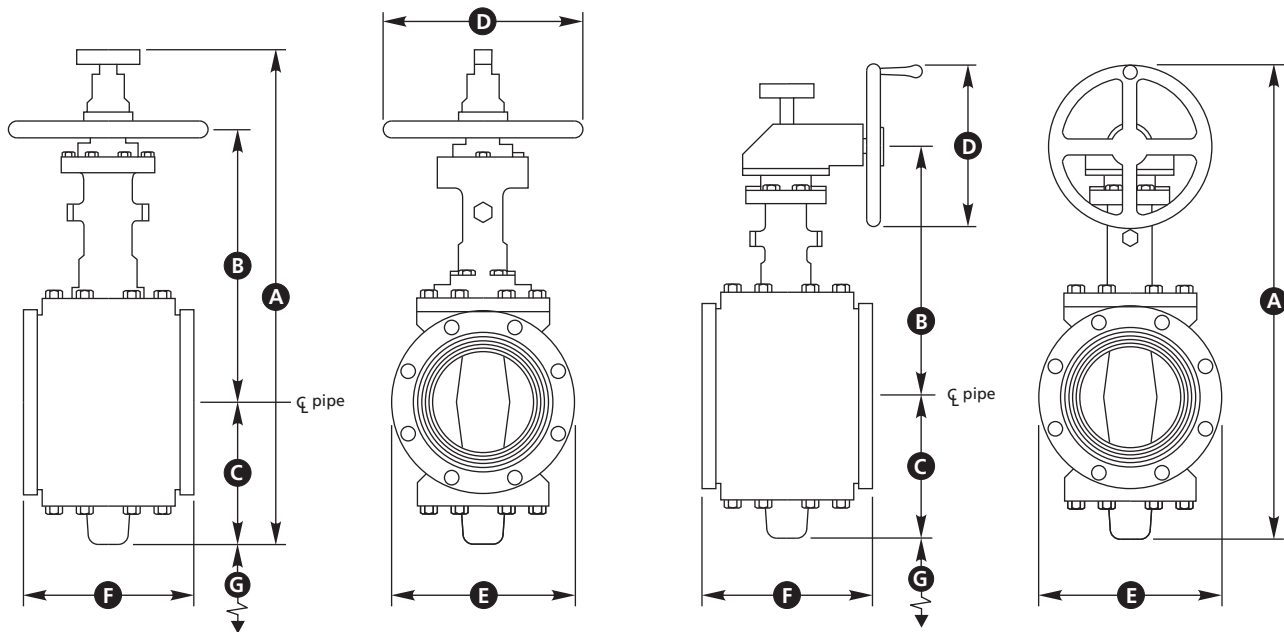

DIMENSIONS

in.
(mm)

Class	Size	Model	Oper	A	B	C	D	E	F	G	lb. (kg)	C _v in GPM
ASME 150 Hand Operated	2 (50)	211	201	21 1/4 (540)	11 7/8 (302)	5 (127)	10 (254)	6 (152)	7 (178)	3 (76)	60 (27)	200
	3 (80)	211	201	21 1/4 (540)	11 7/8 (302)	5 (127)	10 (254)	7 1/2 (191)	8 (203)	3 (76)	75 (34)	205
	4 (100)	211	201	23 1/2 (597)	12 5/8 (321)	6 3/8 (162)	10 (254)	9 (229)	9 (229)	5 (127)	95 (43)	590
	6 (150)	211	202	31 1/8 (790)	16 3/4 (426)	8 5/8 (219)	14 (356)	11 (279)	10 1/2 (266)	8 (203)	195 (88)	1254
ASME 300 Hand Operated	2 (50)	221	201	21 1/4 (540)	11 7/8 (302)	5 (127)	10 (254)	6 1/2 (165)	8 1/2 (216)	3 (76)	65 (29)	210
	3 (80)	221	201	21 1/4 (540)	11 7/8 (302)	5 (127)	10 (254)	8 1/4 (210)	11 1/8 (283)	3 (76)	90 (41)	220
	4 (100)	221	202	25 7/8 (657)	15 (381)	5 1/8 (130)	14 (356)	10 (254)	12 (305)	6 (152)	145 (66)	620
ASME 600 Hand Operated	2 (50)	241	202	24 3/4 (629)	13 7/8 (353)	5 1/8 (130)	14 (356)	6 1/2 (165)	11 1/2 (292)	3 (76)	115 (52)	290
	3 (80)	241	202	24 3/4 (629)	13 7/8 (353)	5 1/8 (130)	14 (356)	8 1/4 (210)	14 (356)	3 (76)	135 (61)	300
	4 (100)	241	203	31 7/8 (810)	18 (457)	7 3/8 (187)	16 (406)	10 3/4 (273)	17 (432)	4 (102)	240 (109)	850
ASME 150 Gear Operated	6 (150)	211	202G	31 7/8 (810)	18 1/4 (464)	8 5/8 (219)	10 (254)	11 (279)	10 1/2 (267)	8 (203)	200 (91)	1254
ASME 300 Gear Operated	4 (100)	221	202G	26 5/8 (676)	16 1/2 (419)	5 1/8 (130)	10 (254)	10 (254)	12 (305)	6 (152)	155 (70)	620
ASME 600 Gear Operated	2 (50)	241	202G	25 1/2 (648)	15 3/8 (391)	5 1/8 (130)	10 (254)	6 1/2 (165)	11 1/2 (292)	3 (76)	120 (54)	290
	3 (80)	241	202G	25 1/2 (648)	15 3/8 (391)	5 1/8 (130)	10 (254)	8 1/4 (210)	14 (356)	3 (76)	140 (64)	300
	4 (100)	241	203G	33 7/8 (861)	19 1/2 (495)	7 3/8 (187)	14 (356)	10 3/4 (273)	17 (432)	4 (102)	265 (120)	850

GENERAL TWIN SEAL 8800

Handwheel Operated

Gear Operated

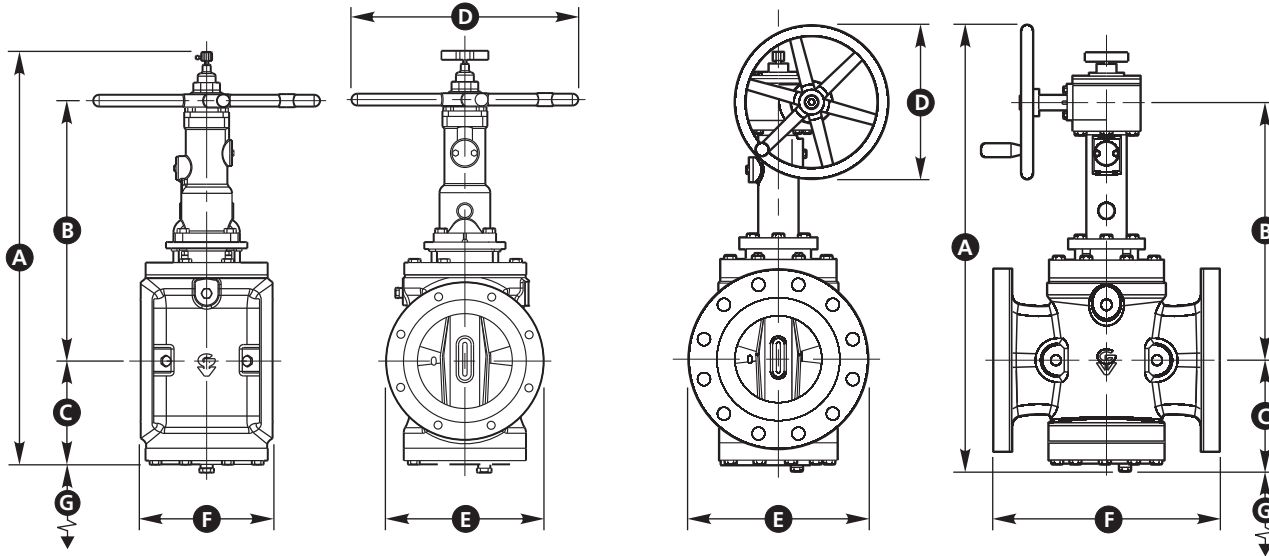

DIMENSIONS
in.
(mm)

Maximum Overall Height
Centerline of Valve to Centerline of Handwheel
Centerline of Valve to Lowest Point
Handwheel Diameter
Flange Diameter
Face-to-Face
Minimum Clearance to Remove Slip from Bottom
Approximate Weight
Flow Coefficient

Class	Size	Model	Oper.	A	B	C	D	E	F	G	lb. (kg)	C _v in GPM
ASME 150 Hand Operated	8 (200)	8811	625H	36 (914)	23 (584)	9 (229)	20 (508)	13 1/2 (343)	11 1/2 (292)	12 1/2 (318)	385 (175)	2420
ASME 300 Hand Operated	6 (150)	8821	625H	32 1/2 (826)	21 (533)	7 1/2 (191)	20 (508)	12 1/2 (318)	15 7/8 (403)	9 (229)	250 (113)	1770
	8 (200)	8811	625G	39 3/4 (1010)	23 (584)	9 3/4 (248)	14 (356)	13 1/2 (343)	11 1/2 (292)	12 1/2 (318)	405 (184)	2420
	10 (250)	8811	625G	42 (1067)	24 (610)	11 (279)	14 (356)	16 (406)	13 (330)	15 (381)	518 (235)	3578
	12 (300)	8811	751G	53 (1346)	30 1/2 (775)	13 (330)	20 (508)	19 (483)	14 (356)	17 (432)	790 (358)	4000
	14 (350)	8811	751G	56 1/4 (1429)	31 3/4 (806)	14 3/4 (375)	20 (508)	21 (533)	15 (381)	19 (483)	995 (451)	5500
ASME 150 Gear Operated	16 (400)	8811	1261G	64 (1626)	38 (965)	16 1/4 (413)	20 (508)	23 1/2 (597)	16 (406)	22 (559)	1340 (608)	7000
	18 (450)	8811	1261G	64 1/4 (1632)	38 (965)	16 1/4 (413)	20 (508)	25 (635)	17 (432)	23 (584)	1407 (638)	7000
	20 (500)	8811	1261G	68 (1727)	39 3/4 (1010)	16 1/4 (413)	20 (508)	27 1/2 (699)	32 (813)	26 (660)	2860 (1297)	15700
	24 (600)	8811	1261G	72 3/4 (1848)	41 1/2 (1054)	21 1/2 (546)	20 (508)	32 (813)	36 (914)	28 (711)	3830 (1737)	24000
ASME 300 Gear Operated	6 (150)	8821	625G	36 (914)	21 1/4 (540)	7 3/4 (197)	14 (356)	12 1/2 (318)	15 7/8 (403)	9 (229)	312 (142)	1770
ASME 900 Gear Operated	2 (50)	8851	625G	31 3/4 (806)	19 (483)	5 3/4 (146)	14 (356)	8 1/2 (216)	14 1/2 (368)	4 (102)	250 (113)	160
	3 (80)	8851	625G	31 3/4 (806)	19 (483)	5 3/4 (146)	14 (356)	9 1/2 (241)	15 (381)	4 (102)	271 (123)	250
ASME 1500 Gear Operated	2 (50)	8861	625G	31 3/4 (806)	19 (483)	5 3/4 (146)	14 (356)	8 1/2 (216)	14 1/2 (368)	4 (102)	250 (113)	160

GENERAL TWIN SEAL 800

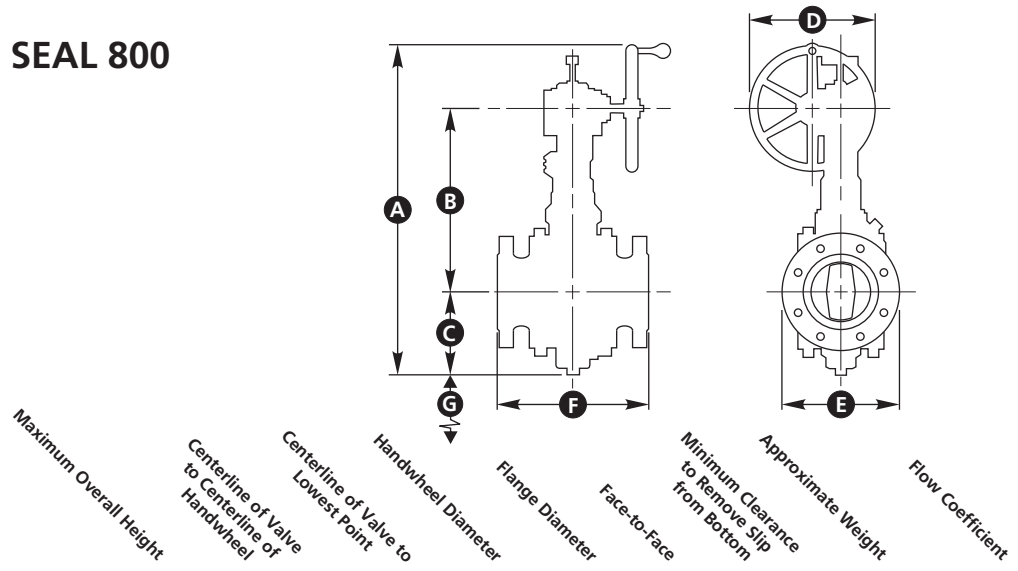

DIMENSIONS
in.
(mm)

Class	Size	Model	Oper.	A	B	C	D	E	F	G	lb. (kg)	C _v in GPM
ASME 150 Gear Operated	28 (700)	C811	1276G	108 1/2 (2756)	60 1/2 (1537)	32 (813)	32 (813)	36 1/2 (927)	60 (1524)	30 (762)	13000 (5897)	31000
	30 (750)	CC811	1276G	108 1/2 (2756)	60 1/2 (1537)	32 (813)	32 (813)	38 3/4 (984)	60 (1524)	30 (762)	13900 (6305)	33000
	36 (900)	C811	1500G	121 (3073)	76 (1930)	34 (864)	32 (813)	46 (1168)	78 (1981)	30 (762)	20600 (9344)	48000
ASME 300 Gear Operated	8 (200)	C821	751G	49 1/2 (1257)	28 (711)	11 (279)	20 (508)	15 (381)	16 1/2 (419)	11 (279)	666 (302)	3000
	10 (250)	C821	751G	52 (1321)	29 (737)	12 1/2 (318)	20 (508)	17 1/2 (445)	18 (457)	13 (330)	888 (403)	3540
	12 (300)	C821	1261G	63 1/2 (1613)	36 1/2 (927)	16 1/2 (419)	20 (508)	20 1/2 (521)	19 3/4 (502)	16 (406)	1414 (641)	4700
	14 (350)	C821	1261G	58 1/2 (1486)	34 1/2 (876)	14 1/2 (368)	20 (508)	23 (584)	30 (762)	15 (381)	1990 (903)	6000
	16 (400)	CA821	1261-7G	61 (1549)	36 1/2 (927)	14 (356)	20 (508)	25 1/2 (648)	33 (838)	19 (483)	2662 (1207)	9400
	18 (450)	CA821	1261-7G	71 (1803)	40 1/2 (1029)	20 1/2 (521)	20 (508)	28 (711)	36 (914)	13 (330)	3550 (1610)	11500
	20 (500)	CA821	1276G	88 1/2 (2248)	48 (1219)	24 1/2 (622)	32 (813)	30 1/2 (775)	39 (991)	14 (356)	4155 (1885)	16300
	24 (600)	CA821	1276G	92 (2337)	50 1/2 (1283)	25 1/2 (648)	32 (813)	36 (914)	52 (1321)	17 (432)	8150 (3697)	27000
	28 (700)	CA821	1500G	114 (2896)	70 (1778)	28 (711)	32 (813)	36 1/4 (921)	65 (1651)	12 (305)	12800 (5806)	32000
30 (750)	CA821	1500G	120 (3048)	71 (1803)	32 1/2 (826)	32 (813)	43 (1092)	65 (1651)	28 (711)	15300 (6940)	33500	
ASME 600 Gear Operated	6 (150)	C841	751G	45 (1143)	26 (660)	9 (229)	20 (508)	14 (356)	22 (559)	10 (254)	696 (316)	2265
	8 (200)	CA841	755G	48 (1219)	27 (686)	11 (279)	20 (508)	16 1/2 (419)	26 (660)	12 (305)	1102 (500)	3600
	10 (250)	CB841	1261-7G	62 1/2 (1588)	36 1/2 (927)	16 (406)	20 (508)	20 (508)	31 (787)	8 (203)	1974 (895)	5100
	12 (300)	CB841	1261-7G	64 1/2 (1638)	38 (965)	17 (432)	20 (508)	22 (559)	33 (838)	10 (254)	2532 (1148)	9300
	14 (350)	C841	1276G	82 1/2 (2096)	47 (1194)	19 1/2 (495)	32 (813)	23 3/4 (603)	35 (889)	10 (254)	4100 (1860)	9500
	16 (400)	CA841	1276G	83 (2108)	47 (1194)	19 1/2 (495)	32 (813)	27 (686)	39 (991)	14 (356)	4300 (1950)	11000
	20 (500)	C841	1500G	106 (2692)	66 (1676)	23 1/2 (597)	32 (813)	32 (813)	47 (1194)	14 (356)	9500 (4309)	16500
	24 (600)	C841	1500G	114 (2896)	72 (1829)	26 (660)	32 (813)	37 (940)	55 (1397)	12 (305)	15000 (680)	27000
ASME 900 Gear Operated	4 (100)	C851	625G	37 1/2 (953)	20 (508)	10 (254)	14 (356)	11 1/2 (292)	18 (457)	6 (152)	397 (180)	650
	6 (150)	C851	755G	47 1/2 (1207)	26 (660)	11 1/2 (292)	20 (508)	15 (381)	24 (610)	7 1/2 (191)	975 (442)	2400
	8 (200)	C851	1261-7G	63 1/2 (1613)	37 (940)	16 1/2 (419)	20 (508)	18 1/2 (470)	29 (737)	10 (254)	1440 (653)	4200
	10 (250)	C851	1276G	88 1/2 (2248)	51 1/2 (1308)	21 (533)	32 (813)	21 1/2 (546)	33 (838)	10 (254)	3600 (1633)	5500
ASME 1500 Gear Operated	3 (80)	C861	625G	34 (864)	19 (483)	8 (203)	14 (356)	10 1/2 (267)	18 1/2 (470)	4 (102)	280 (127)	250

GENERAL TWIN SEAL 400

SHORT PATTERN

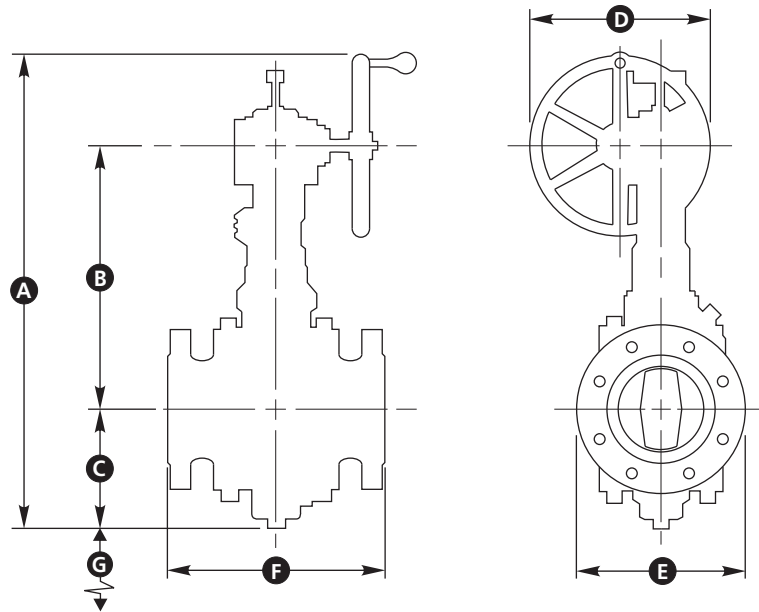

DIMENSIONS

in.
(mm)

Class	Size	Model	Oper.	DIMENSIONS							lb. (kg)	C _v in GPM
				A	B	C	D	E	F	G		
ASME 150	6 (150)	C411	501 TS	30 (762)	16 1/2 (419)	8 1/2 (216)	10 (254)	11 (279)	10 1/2 (267)	4 1/2 (114)	140 (64)	760
	8 (200)	C411	625 TS	37 (940)	20 1/2 (521)	9 (229)	14 (356)	13 1/2 (343)	11 1/2 (292)	8 (203)	214 (97)	1250
	10 (250)	C411	625 TS	40 (1016)	22 (559)	11 (279)	14 (356)	16 (406)	13 (330)	11 (279)	436 (198)	2400
	12 (300)	C411	751 TS	51 1/2 (1308)	29 1/2 (749)	12 (305)	20 (508)	19 (483)	14 (356)	12 1/2 (316)	532 (241)	4100
	16 (400)	C411	751 TS	55 1/2 (1410)	31 (787)	15 (381)	20 (508)	23 1/2 (597)	16 (406)	19 (483)	1074 (487)	5200
	18 (450)	C411	1261 TS	67 (1702)	38 1/2 (978)	18 (457)	20 (508)	25 (635)	17 (432)	17 (432)	1488 (675)	7000
	20 (500)	C411	1261 TS	70 (1778)	40 (1016)	20 (508)	20 (508)	27 1/2 (699)	18 (457)	22 (559)	2658 (1206)	8500
	24 (600)	C411	1261 TS	74 1/2 (1892)	42 1/2 (1080)	22 (559)	20 (508)	32 (813)	20 (508)	28 (711)	3326 (1509)	11250
ASME 300	6 (150)	C421	501 TS	30 (762)	16 1/2 (419)	8 1/2 (216)	10 (254)	12 1/2 (318)	16 (406)	4 1/2 (114)	162 (73)	900
	8 (200)	C421	625 TS	37 (940)	20 1/2 (521)	9 (229)	14 (356)	15 (381)	16 1/2 (419)	8 (203)	348 (158)	1450
	10 (250)	C421	751 TS	49 1/2 (1257)	28 (711)	11 (2791)	20 (508)	17 1/2 (445)	18 (457)	11 (279)	666 (302)	2750
	12 (300)	C421	751 TS	51 1/2 (1308)	29 1/2 (749)	12 1/2 (318)	20 (508)	20 1/2 (521)	19 3/4 (502)	12 1/2 (316)	888 (403)	4800
	20 (500)	C421	1261.7 TS	60 3/4 (1543)	36 1/2 (927)	14 (356)	20 (508)	30 1/2 (775)	39 (991)	22 (559)	3550 (1610)	10000
	24 (600)	C421	1276 TS	77 3/4 (1975)	44 3/4 (1137)	17 (432)	32 (813)	36 (914)	45 (1143)	28 (711)	4155 (1885)	16000
ASME 600	6 (150)	C441	625 TS	34 (864)	19 1/4 (489)	8 (203)	14 (508)	14 (356)	22 (559)	8 (203)	276 (125)	1050
	8 (200)	C441	751 TS	45 1/2 (1156)	26 (660)	9 1/4 (235)	20 (508)	16 1/2 (419)	26 (660)	11 (279)	696 (316)	1600
	10 (250)	C441	751 TS	48 (1219)	27 1/4 (692)	10 3/4 (273)	20 (508)	20 (508)	31 (787)	12 1/2 (316)	1102 (500)	NA
	18 (450)	C441	1276 TS	82 1/2 (2096)	47 (1194)	19 1/2 (495)	32 (813)	29 1/4 (743)	39 (991)	10 (254)	4300 (1950)	NA

GENERAL TWIN SEAL 900 FULL BORE PIGGABLE

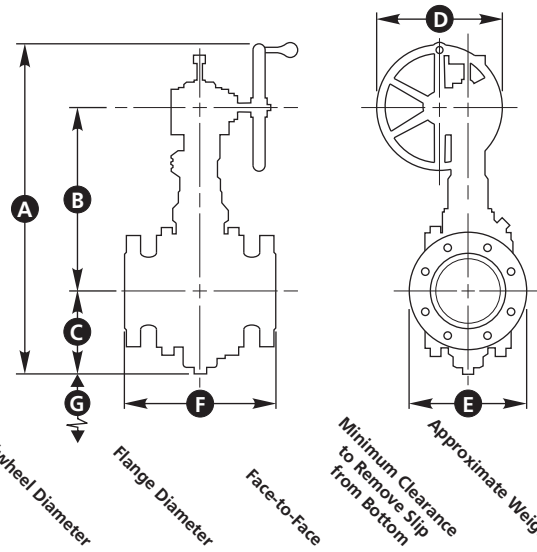

DIMENSIONS
in.
(mm)

Class	Size	Model	Oper.	A	B	C	D	E	F	G	lb. (kg)
ASME 150	2 (50)	C911	501 TS	26 (660)	15 (381)	6 (152)	10 (254)	6 (152)	10 1/2 (267)	5 (127)	216 (98)
	3 (80)	C911	501 TS	28 (711)	16 (406)	7 (178)	10 (254)	7 1/2 (191)	13 1/2 (343)	5 (127)	320 (145)
	4 (100)	C911	501 TS	32 (813)	17 1/2 (445)	7 (178)	10 (254)	9 (229)	17 (432)	5 (127)	401 (182)
	6 (150)	C911	625 TS	37 (940)	21 (533)	9 (229)	14 (356)	11 (279)	21 (533)	7 1/2 (191)	522 (237)
	8 (200)	C911	751 TS	48 (1219)	27 1/2 (699)	10 1/2 (267)	20 (508)	13 1/2 (343)	25 (635)	9 (229)	861 (390)
	10 (250)	C911	751 TS	52 1/2 (1334)	29 (737)	13 1/2 (343)	20 (508)	16 (406)	31 (787)	11 (279)	1275 (578)
	12 (300)	C911	1261 TS	60 (1524)	35 (889)	15 (381)	20 (508)	19 (483)	36 (914)	14 (356)	1670 (757)
	14 (350)	C911	1261 TS	61 1/2 (1562)	36 (914)	15 1/2 (394)	20 (508)	21 (533)	34 (864)	15 (381)	2406 (1091)
	16 (400)	C911	1261 TS	64 (1626)	37 (940)	17 (432)	20 (508)	23 1/2 (597)	35 (889)	17 (432)	3006 (1363)
	18 (450)	C911	1261.7 TS	78 (1981)	44 1/2 (1130)	23 1/2 (597)	20 (508)	25 (635)	48 (1219)	18 (457)	5700 (2585)
20 (500)	C911	1261.7 TS	78 1/2 (1994)	44 1/2 (1130)	24 1/2 (622)	20 (508)	27 1/2 (699)	48 (1219)	17 (432)	6165 (2796)	
24 (600)	C911	1276 TS	108 1/2 (2756)	60 1/2 (1537)	32 (813)	32 (813)	32 (813)	60 (1524)	30 (762)	12800 (5806)	
ASME 300	2 (50)	C921	501 TS	26 (660)	15 (381)	6 (152)	10 (254)	6 (152)	11 1/8 (283)	5 (127)	350 (159)
	4 (100)	C921	501 TS	29 1/2 (749)	16 1/2 (419)	7 1/2 (191)	10 (254)	10 (254)	18 (457)	6 (152)	365 (165)
	6 (150)	C921	625 TS	38 (965)	21 (533)	10 (254)	14 (356)	12 1/2 (318)	22 (559)	8 (203)	615 (279)
	8 (200)	C921	1261 TS	55 (1397)	33 (838)	12 (305)	20 (508)	15 (381)	27 (686)	9 (229)	1255 (569)
	10 (250)	CA921	1261 TS	58 1/2 (1486)	34 1/2 (876)	14 (356)	20 (508)	17 1/2 (445)	32 1/2 (826)	12 (305)	1800 (816)
	12 (300)	CA921	1261.7 TS	59 (1499)	35 (889)	14 (356)	20 (508)	20 1/2 (521)	38 (965)	16 (406)	2500 (1134)
	16 (400)	C921	1276 TS	83 (2108)	48 (1219)	19 (483)	32 (813)	25 1/2 (648)	35 (889)	16 (406)	4000 (1814)
20 (500)	CA921	1276 TS	89 1/2 (2273)	50 1/2 (1283)	23 (584)	32 (813)	30 1/2 (775)	48 (1219)	19 (483)	7000 (3175)	
ASME 600	2 (50)	C941	625 TS	32 1/2 (826)	19 (483)	6 1/2 (165)	14 (356)	6 1/2 (165)	13 (330)	6 (152)	400 (181)
	4 (100)	C941	625 TS	34 (864)	19 1/2 (495)	8 (203)	14 (356)	10 3/4 (273)	17 (432)	6 (152)	610 (277)
	6 (150)	C941	751 TS	47 (1194)	27 (686)	10 1/2 (267)	20 (508)	14 (356)	22 (559)	8 (203)	1100 (499)
	12 (300)	C941	1276 TS	83 (2108)	47 (1194)	19 1/2 (495)	32 (813)	22 (559)	33 (838)	10 (254)	4200 (1905)
	14 (350)	C941	1500 TS	106 (2108)	66 (1676)	26 (660)	32 (813)	27 (686)	39 (991)	15 (381)	9500 (4309)
	16 (400)	C941	1500 TS	106 (2692)	66 (1676)	24 (610)	32 (813)	27 (686)	39 (991)	16 (406)	9500 (4309)
20 (500)	C941	1500TS	114 (2896)	72 (1829)	29 1/2 (749)	32 (813)	32 (813)	55 (1397)	20 (508)	14000 (6350)	

**GENERAL TWIN SEAL
SEAT & RESEAT VALVE**

LETS YOU CHANGE SEALS IN MINUTES - WITHOUT DRAINING THE LINE

You can forget about line draining, line flushing, vacuum trucks and product losses - General's Twin Seal Seat and Reseat valve eliminates them all.

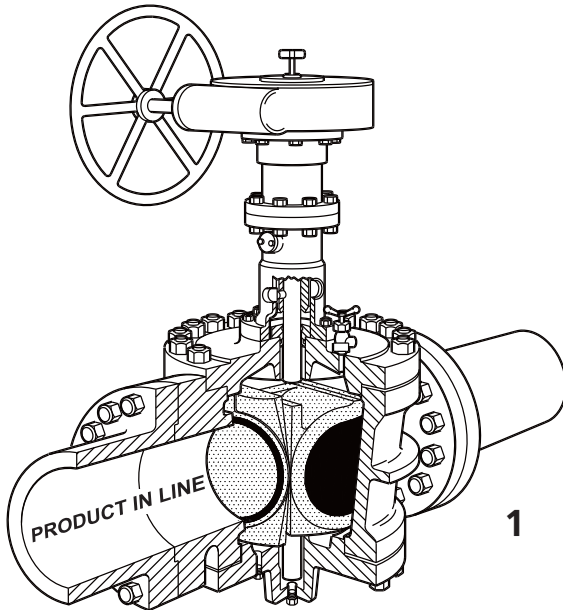

VALVE IN CLOSED POSITION

Resilient seals form bubble-tight shut-off on upstream and downstream ports and secondary metal-to-metal seats provide sufficient shut-off to meet fire safety requirements.

The bonnet-mounted manual or automatic bleed valve verifies zero leakage, perfect shut-off.

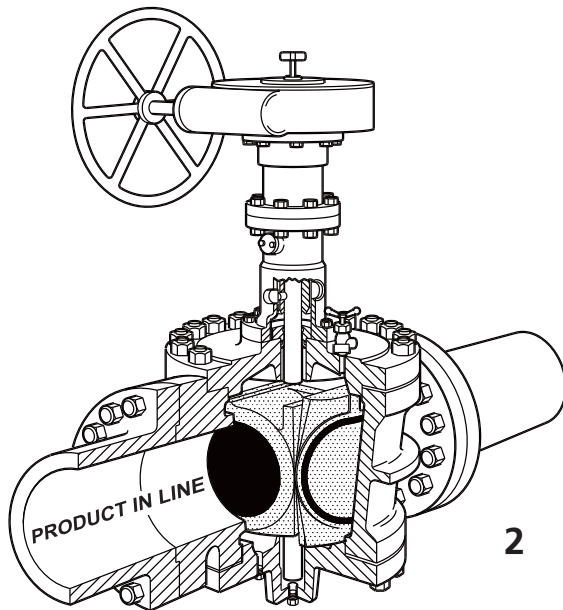

**VALVE IN OPEN POSITION,
PRODUCT IN LINE**

After seating segments are mechanically retracted from the ports, the plug is rotated 90 degrees and resealed into tapered body seats in the open position and a metal-to-metal seat is formed. Line rouge (sediment) from "pigging" is prevented from settling in the body cavity.

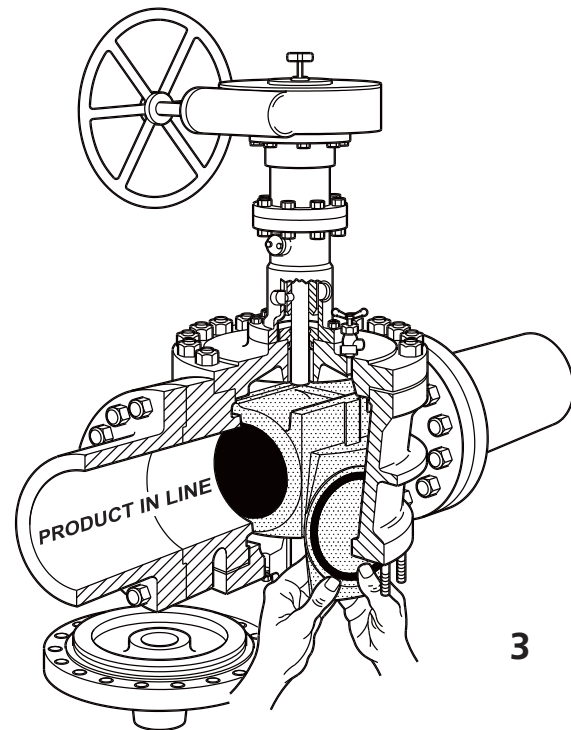

**VALVE STILL IN OPEN POSITION,
PRODUCT IN LINE**

The body bleed feature verifies there is no pressure in the body cavity. The line need not be drained. The bottom plate can now be removed safely and new seating segments can be slipped into position. Only common hand tools are needed for the entire procedure.

**GENERAL TWIN SEAL
SEAT & RESEAT 1600
REDUCED BORE**

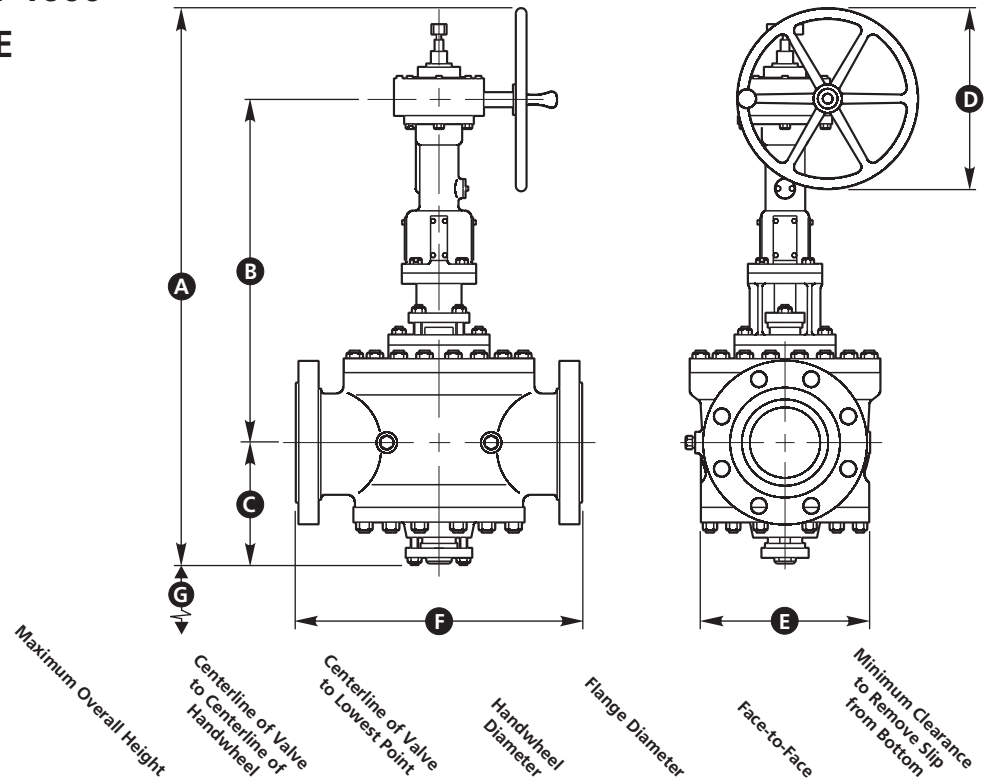

DIMENSIONS
in.
(mm)

Class	Size	Model	A	B	C	D	E	F	G
ASME 150	8 (200)	C1611	47 1/2 (1207)	27 (686)	10 1/2 (267)	20 (508)	13 1/2 (343)	16 1/2 (419)	7 1/2 (191)
	12 (300)	C1611	58 1/2 (1486)	36 (914)	13 (330)	20 (508)	19 (483)	32 1/2 (826)	11 1/2 (292)
ASME 300	6 (150)	C1621	37 (940)	22 (559)	8 (203)	14 (356)	12 1/2 (318)	15 7/8 (403)	5 (127)
	8 (200)	C1621	47 1/2 (1207)	27 (686)	10 1/2 (267)	20 (508)	15 (381)	16 1/2 (419)	7 1/2 (191)
	10 (250)	C1621	51 (1295)	29 1/2 (749)	11 1/2 (292)	20 (508)	17 1/2 (445)	18 (457)	12 (305)
	12 (300)	C1621	58 1/2 (1486)	36 (914)	13 (330)	20 (508)	20 1/2 (521)	32 1/2 (826)	11 1/2 (292)
	14 (350)	C1621	54 1/2 (1384)	32 (813)	13 (330)	20 (508)	23 (584)	30 (762)	12 (305)
ASME 600	20 (500)	C1621	95 1/2 (2426)	57 (1448)	22 1/2 (572)	32 (813)	30 1/2 (775)	46 (1168)	12 (305)
	6 (150)	C1641	37 (940)	22 (559)	8 1/2 (216)	14 (356)	14 (356)	22 (559)	5 (127)
	8 (200)	C1641	47 (1194)	27 1/2 (699)	9 1/2 (241)	20 (508)	16 1/2 (419)	26 (660)	7 1/2 (191)
	10 (250)	C1641	64 1/2 (1638)	38 (965)	16 1/2 (419)	20 (508)	20 (508)	31 (787)	11 1/2 (292)
ASME 900	6 (150)	C1651	57 1/2 (1461)	35 1/2 (902)	12 (305)	20 (508)	15 (381)	24 (610)	5 (127)
	8 (200)	C1651	71 (1803)	44 1/2 (1130)	17 (432)	20 (508)	18 1/2 (470)	29 (737)	5 (127)
	10 (250)	C1651	87 (2210)	53 1/2 (1359)	18 (457)	32 (813)	21 1/2 (546)	33 (838)	8 (203)
	14 (350)	C1651	106 (2692)	70 (1778)	20 (508)	32 (813)	29 1/2 (749)	-	15 (381)
ASME 1500	3 (80)	C1661	46 (1168)	33 1/2 (851)	5 1/2 (140)	14 (356)	10 1/2 (267)	18 1/2 (470)	3 1/2 (89)
	4 (100)	C1661	57 1/2 (1461)	36 (914)	11 1/2 (292)	20 (508)	12 1/4 (311)	21 1/2 (546)	4 1/2 (114)
	6 (150)	C1661	56 (1422)	34 (864)	12 1/2 (318)	20 (508)	15 1/2 (394)	27 3/4 (705)	5 (127)
	12 (300)	C1661	107 (2718)	70 (1778)	21 (533)	32 (813)	26 1/2 (673)	-	6 1/2 (165)

**GENERAL TWIN SEAL
SEAT & RESEAT 1500
FULL BORE PIGABLE**

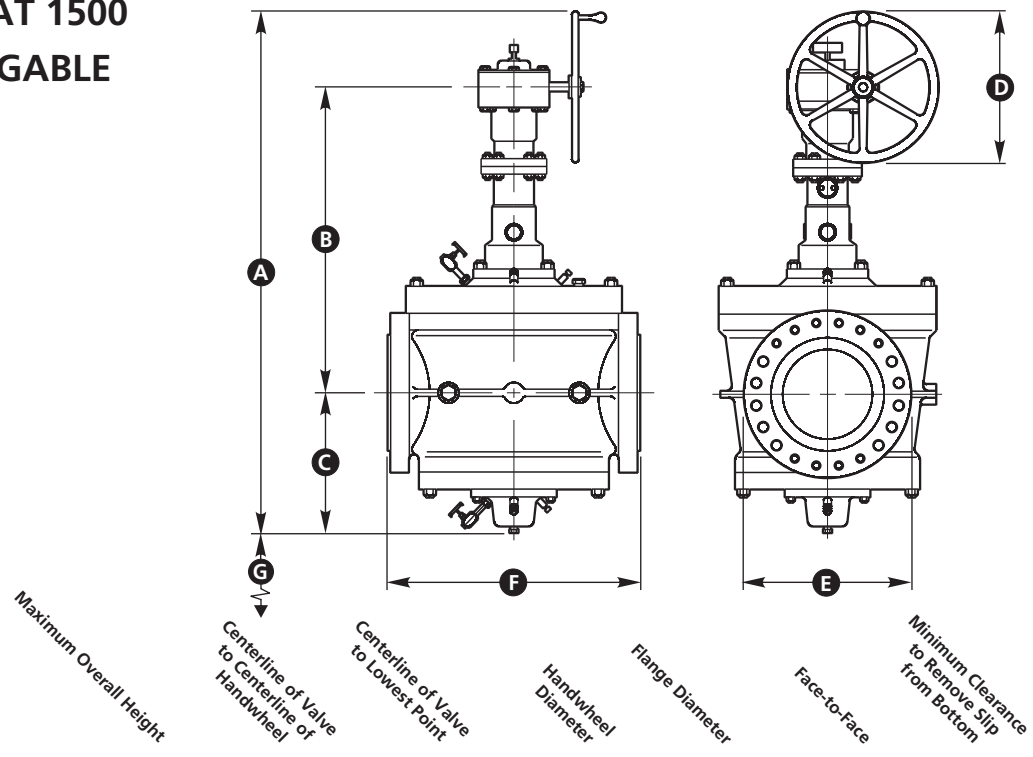

DIMENSIONS
in.
(mm)

Class	Size	Model	A	B	C	D	E	F	G
ASME 150	18 (450)	C1511	95 1/2 (2426)	56 (1422)	23 1/2 (597)	32 (813)	25 (635)	48 (1219)	16 1/2 (419)
	20 (500)	C1511	105 (2667)	65 1/2 (1664)	23 1/2 (597)	32 (813)	27 1/2 (699)	48 (1219)	16 (406)
	24 (600)	C1511	92 (2337)	51.5 (1308)	32 (813)	32 (813)	32 (813)	-	30 (7620)
ASME 300	6 (150)	C1521	48 (1219)	28 (711)	10 (254)	20 (508)	12 1/2 (318)	15 7/8 (403)	9 1/2 (241)
	10 (250)	C1521	66 1/2 (1689)	44 (1118)	13 (330)	20 (508)	17 1/2 (445)	32 1/2 (826)	10 1/2 (267)
	18 (450)	C1521	106 1/2 (2705)	67 (1702)	23 1/2 (597)	32 (813)	28 (711)	48 (1219)	15 1/2 (394)
	24 (600)	C1521	122.5 (3112)	77.5 (1969)	29 (737)	32 (813)	36 (914)	-	19 (483)
ASME 600	6 (150)	C1541	49 1/2 (1257)	29 (737)	10 1/2 (267)	20 (508)	14 (356)	22 (559)	8 (203)
	8 (200)	C1541	63 (1600)	37 (940)	16 (406)	20 (508)	16 1/2 (419)	26 (660)	10 (254)
	10 (250)	C1541	64 1/2 (1638)	38 1/2 (978)	16 (406)	20 (508)	20 (508)	31 (787)	12 (305)
	12 (300)	C1541	82 (2083)	47 (1194)	19 (483)	32 (813)	22 (559)	33 (838)	14 (356)
	16 (400)	C1541	107 (2718)	66 (1676)	25 (635)	32 (813)	27 (686)	44 1/2 (1130)	15 (381)
ASME 900	6 (150)	C1551	67 1/2 (1715)	42 1/2 (1080)	15 (381)	20 (508)	15 (381)	24 (610)	4 (102)
	8 (200)	C1551	72 1/2 (1842)	45 (1143)	18 (457)	20 (508)	18 1/4 (464)	29 (737)	4 1/2 (114)
	10 (250)	C1551	80 (2032)	46 (1168)	18 (457)	32 (813)	21 1/2 (546)	33 (838)	7 (178)
	12 (300)	C1551	108 (2743)	70 (1778)	22 1/2 (572)	32 (813)	24 (610)	38 (965)	7 1/2 (191)
ASME 1500	6 (150)	C1561	66 (1676)	41 (1041)	15 (381)	20 (508)	15 1/2 (394)	27 3/4 (705)	2 1/2 (64)
	8 (200)	C1561	84 1/2 (2146)	50 1/2 (1283)	18 (457)	32 (813)	19 (483)	32 3/4 (832)	4 1/2 (114)
	10 (250)	C1561	108 1/2 (2756)	71 1/2 (1816)	21 1/2 (546)	32 (813)	23 (584)	39 (991)	5 (127)
	12 (300)	C1561	108 1/2 (2756)	71 1/2 (1816)	22 (559)	32 (813)	26 1/2 (673)	44 1/2 (1130)	6 1/2 (165)

TWIN SEAL ELECTRIC ACTUATORS

TWIN SEAL Valves accept most commercially available electric motor operators.

All Automated TWIN SEAL Valves require some form of body pressure relief because of thermal expansion (see page 17 & 18) (MBV/DTR/ABV/etc); otherwise the valve may be difficult to Open or may stick in the Closed Position.

Choice of Motor Size

The best selection of valve, gearing and motor operator will depend on a number of factors including:

- Pipeline Pressure
- Operating Speed
- Environmental Conditions
- Handwheel Accessibility
- Available Power

Selecting the correct motor is a specialist task.

Consult your TWIN SEAL Representative for free technical advice.



Typical Mounting Configurations*

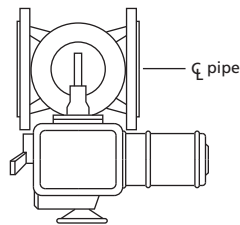

Style "A": Actuator mounted parallel to pipe line.

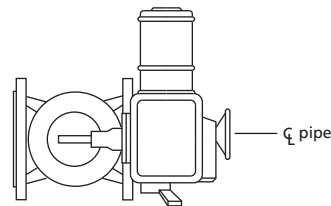

Style "B": Actuator mounted at right angle to pipe line.

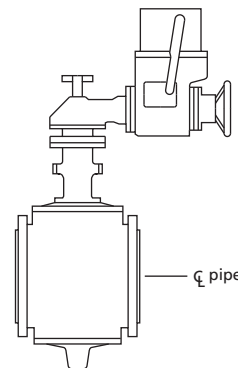
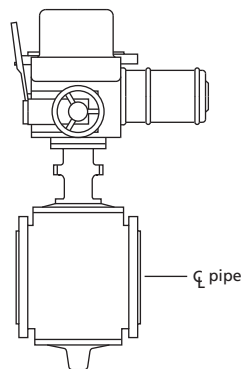

*Specific handwheel location will depend on type of actuator used.

GENERAL TRUSEAL PNEUMATIC ACTUATORS

Cameron builds pneumatic actuators that can be fitted to General TruSeal valves for reliable, economic power operation.

When you specify a complete actuated valve package, the entire system is built, tested and guaranteed by Cameron.

Only a few of the available power operation choices are shown on this page.

For complete information contact the company office nearest you for alternative packages.

Spring-close Piston Actuators

- For emergency shut-down service.
- Air-to-open. Spring to-close.
- Fitted with gas/oil speed control snubber system and two-way manual override handwheel.
- Valve can be mechanically locked closed or mechanically locked open.
- Limit switches can be fitted for remote indication of the valve position.

Double-acting Diaphragm Actuator with Reservoir Tank

- For continued operation in case of air supply failure.
- Piston-type grease snubber for speed control.
- Position indicator limit switch for local and remote indication of valve position.
- Fitted with a complete instrumentation package for:
 - Fail close or
 - Fail in last position

Spring-close Diaphragm Actuator

- Air-to-open. Spring-to-close.
- Fitted with integral gas/oil speed control snubber system.
- Position indicator limit switches for local and remote indication of valve position.
- Fitted with a complete instrumentation package for:
 - Close on Loss of Air supply
 - Close on Loss of Signal
 - Open on Command
 - Close on Command
 - Pressure gauge is included for proof of zero-leak shut-off.



Spring-close Piston Actuator



Double-acting Diaphragm Actuator with Reservoir Tank



Spring-close Diaphragm Actuator

GENERAL TWIN SEAL LIMIT SWITCHES



General Twin Seal can be fitted with switches or sensors to provide Open/Closed position indication of the valve.

The switches or sensors are housed within a proprietary enclosure which meets the latest National and International electrical and explosion proof standards.



MECHANICAL EXTENSIONS

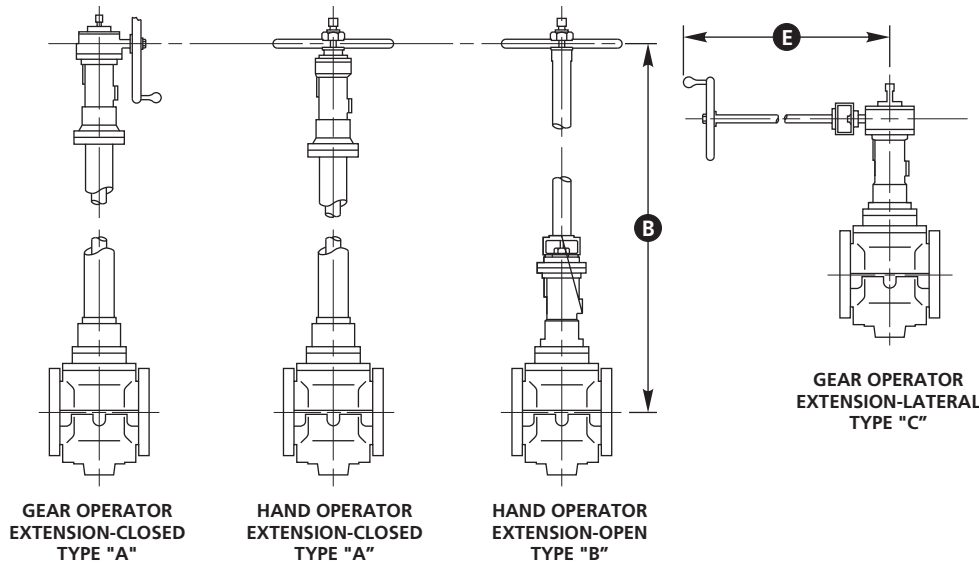

General Twin Seal makes both vertical and lateral extensions or combinations of both. In ordering, always specify dimension B or E. Type A Extension is suitable for underground burial. Type C Extension should be supported if dimension E is over 36 in. (900 mm).

General Twin Seal valves, both hand-operated and gear-operated, can be supplied with chainwheels to operate elevated valves from below.



The chainwheels have an extra deep channel in which the chain runs to assure that the chain will not climb off the track.

The chain is supplied fully trimmed to eliminate barbs, and is galvanized to withstand corrosive conditions.

When ordering chainwheels, give size and series of the valve and the length of chain required.

GENERAL TWIN SEAL DIRECT BURIAL - UNDERGROUND

Patented General Twin Seal Extended Bonnet Valves greatly simplify maintenance in underground applications while providing dependable Double Block and Bleed shut-off.

Most underground valves are difficult to maintain and service, requiring excavation or a costly access pit. System designers often must compromise valve placement to overcome this maintenance problem.

With exclusive General Twin Seal Extended Bonnet Valves, however, the designer has the freedom to put the valves in their ideal locations. Installation costs are minimized.

Easy, Inexpensive Maintenance

Once Extended Bonnet Valves have been installed, maintenance can be performed from above ground without a pit and without excavating.

Unbolting and lifting the bonnet raises the valve plug and slips to ground level. Slip replacement is quick and easy, and downtime is minimal.

Once the slips have been replaced, simply lower the assembly back into position and bolt down the bonnet.



General Twin Seal Hydraulic Extension Systems are available for installations where standard Type A, B, and C extensions are not practical.

Since the self-contained Hydraulic Extension Systems are manually-hydraulically operated, there are virtually no limitations on length and orientation.



The hydraulic extension for gear operators is essentially a hydrostatic transmission.

The pump is driven by a handwheel, and the pressure created is transmitted to the hydraulic motor mounted on the gear operator. This approach allows the system designer maximum flexibility since the only connections between the handwheel and valve are hydraulic tubes.

There is no limitation on the number of corners turned between the valve and handwheel.

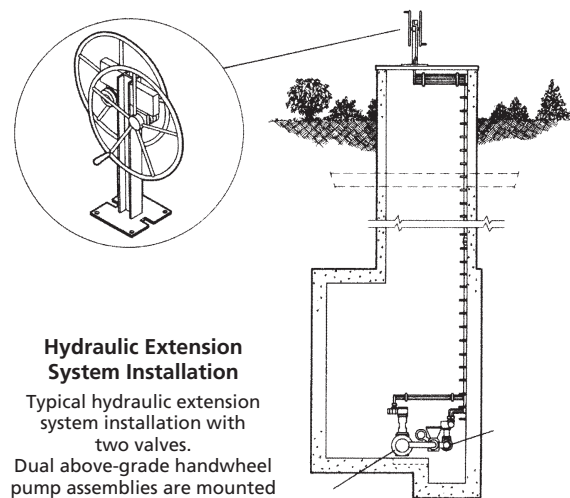

Hydraulic Extension System Installation

Typical hydraulic extension system installation with two valves. Dual above-grade handwheel pump assemblies are mounted on the same pedestal.

GENERAL TWIN SEAL PRESSURE RELIEF SYSTEMS

To satisfy the requirements of API 6D, a pressure relief device must be provided on all double block and bleed valves in liquid service.

When the General Twin Seal valve is seated and completely filled with liquid, even a slight increase in temperature due to the sun's rays will result in a drastic increases in the body cavity pressure resulting from thermal expansion, therefore all Twin Seal valves in liquid service must always be installed with a pressure relief device.

Manual Bleed (MBBV)



A Manual Body Bleed Valve is included on this General Twin Seal. This bleed valve installed in the body cavity is only opened after the General Twin Seal is closed. Seal effectiveness can be immediately evaluated. This bleed valve must be closed before the General Twin Seal is reopened.

Safety Block/DTR



The Safety Block/DTR functions exactly as the basic Safety Bleed. However, all working components are housed in a virtually indestructible compact carbon steel manifold. The benefits of this incident control equipment are: fire safety, complete component access for maintenance purposes, all socket welded joints, heavy wall pipe and total incident control.

Safety Bleed/DTR

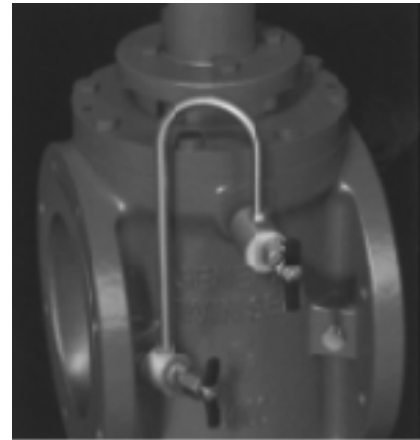

The differential thermal relief system is arranged as shown. The integral relief valve, mounted in the upper relief/vent manifold, routes excess pressure to the upstream throat of the valve. The standard relief valve is set to open at 25 psi above upstream pressure. This system functions only when the valve is closed. A manual body bleed, also integrally mounted in the upper relief/vent manifold, is opened only to vent and verify seal integrity. An isolation valve installed in the upstream throat tap is also included in this system. It must be left open to permit the relief system to relieve pressure upstream.

GENERAL TWIN SEAL PRESSURE RELIEF SYSTEMS

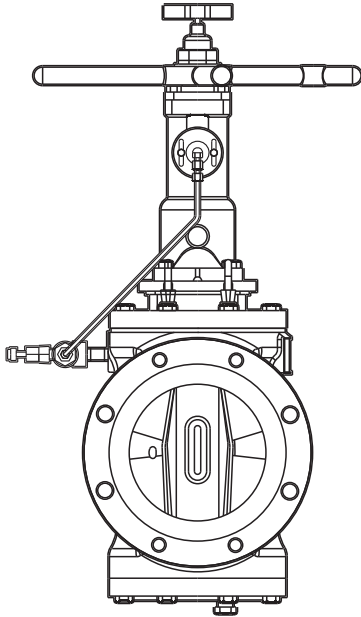

The Automatic Body Bleed Valve (ABBV) provides visual, positive assurance that the Twin Seal has sealed completely at each cycling operation and prevents thermal pressure buildups in the body cavity.

An automatic bleed valve connected to the body cavity of the main valve is mechanically opened by the valve operator when the Twin Seal is seated.

Seal integrity is indicated by viewing the discharge of the bleed valve.

When the Twin Seal is opened, the bleed valve is automatically closed by the combination of line pressure and the spring in the bleed valve.

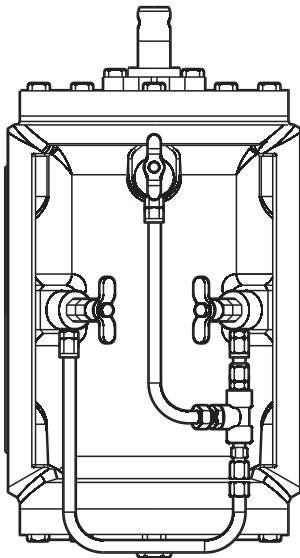

Line Relieving Safety Bleed/DTR

The Line Relieving/Differential Thermal Relief (LR/DTR) provides all the same features as a basic DTR with one additional function, it pressure protects the downstream piping.

A relief valve (25 psid standard) is connected to the downstream throat tap via the lower tee.

When the Twin Seal is seated and the downstream piping is sealed bubble tight, the piping faces thermal over pressurization.

The throat tap accesses this piping and directs any over pressurization upstream. An additional isolation valve is installed downstream for maintenance purpose.

TWIN SEAL

STANDARD MATERIALS OF CONSTRUCTION

Valve Series	200	8800	400/800/900/1500/1600
Body	Cast Carbon Steel - ASTM A216 WCC (1)	Cast Carbon Steel - ASTM A216 WCC (1)	Cast Carbon Steel - ASTM A216 WCB (1)
Bonnet/Lower Plate	Carbon Steel - ASTM A105 Forged Steel (2)	Carbon Steel ASTM A36/A516 Gr. 70 plate (2)	Carbon Steel ASTM A36/A516 Gr. 70 plate (2)
Plug	Ductile Iron ASTM A536 Gr. 80-55-06 (3)	Ductile Iron ASTM A395 Gr. 60-40-18 (3) for valve sizes 8 in. to 12 in. Larger sizes ASTM A216 WCB (3)	Cast Carbon Steel ASTM A216 WCB (3)
Stem	Ductile Iron ASTM A536 Gr. 80-55-06 (3)	ASTM A564 Type 630 17-4 PH SS for valve sizes 8 in. to 12 in.	Cast Carbon Steel ASTM A216 WCB (3)
Slips	Ductile Iron ASTM A536 Gr. 65-45-12 Manganese Phosphate Coated	Ductile Iron ASTM A395 Gr. 60-40-18 Manganese Phosphate Coated	Ductile Iron ASTM A395 Gr. 60-40-18 Manganese Phosphate Coated
Gland	ASTM A216 WCC	ASTM A747 17-4 PH SS	ASTM A36 Plate
Gland Packing	Graphite	Graphite	Graphite
Body Fire Seals	Graphite	Graphite	Graphite
O-Rings & Slip Seals	See trim selection	See trim selection	See trim selection
Fasteners	ASTM A193 Gr. B7/2H	ASTM A193 B7	ASTM A193 Gr. B7/2H

Note: (1) Chrome Plated Bore. (2) Or Cast Equivalent. (3) Electroless Nickel Coated. Materials subject to change without notice.

Proper seal selection includes a number of considerations such as media, pressure class, valve type, differential pressure, low temperature, high temperature, seal type, etc. To that end we have included a selection of slip seal materials and a brief list of considerations:

Twin Seal Trim Selection

Fluoro Elastomers Slip Seal Materials			For more info ask for GVMP5
V	Viton	Our Standard Material Since 1958	3037
V9	Viton 90 Durometer	Standard HIΔP	3042
VFR	Fiber Reinforced Viton	Optional HIΔP	3033
VGF	Viton GF	Viton with Enhanced Chem. Resistance	3043
VGLT	Viton GFLT	Low Temp Viton GF	3044
VGLT9	Viton 90 Durometer GFLT	HIΔP Low Temp Viton GF	3059
Nitrile Elastomers Slip Seal Materials			
H	Nitrile	Our Original Standard Material	3048
H9	Nitrile 90 Durometer	HIΔP Nitrile	3049
LH	Low Temp Nitrile	Low Temp Nitrile	3050
H5	Modified Nitrile	Reformulate Gasoline Seal Material	3053
Specialty Slip Seal Materials			
C	Epichlorohydrin	Good Low Temp Material	3054
E	Ethylenepropylene	Ammonia but not Hydrocarbon	3057
UHS	Fluorosilicone	Good High and Low Temp	3032
RZL	Rezilon	HIΔP RFG	3034
AFL	AFLAS	Amines, exp. decomp., steam, 600°F	3045
GVX	VTR 6279	Ultra Chemical Resistant	3047
T	Teflon	Good for just about anything	3041

All specifications and materials are subject to change without notice.
 TWIN SEAL, GVM, REZILON, VFR, GVX, BEST VALVE BEST VALUE, WHEN LEAKS MATTER, SEAT AND RESEAT, HGO, GOSP, SAFETY BLEED, SAFETY BLOCK AND SAFETY CHECK, VITON and TEFLON are registered trademarks of their respective owners.

TRADEMARK INFORMATION

General Valve® is a registered trademark which is owned by Cameron.

This document contains references to registered trademarks or product designations, which are not owned by Cameron.

Trademark	Owner
Celcon	Hoechst Celanese Corporation
Delrin	E.I. DuPont De Nemours & Company
Fluorel	Minnesota Mining and Manufacturing Company
Hastelloy	Haynes International, Inc
Hycar	Hydrocarbon Chemical and Rubber Company
Hydrin	Zeon Chemicals USA, Inc.
Hypalon	E.I. DuPont De Nemours & Company
Inconel	INCO Nickel Sales, Inc.
Monel	INCO Alloys International, Inc.
Nordel	E.I. DuPont De Nemours & Company
Stellite	Stoody Deloro Stellite, Inc.
Teflon	E.I. DuPont De Nemours & Company
Viton	E.I. DuPont De Nemours & Company

CAMERON, VALVES & MEASUREMENT TERMS AND CONDITIONS OF SALE

1. CONTRACT ACCEPTANCE:

Any written or oral purchase order received from Buyer by Seller shall be construed as a written acceptance of Seller's offer to sell and shall be filled in accordance with the terms and conditions of sale set forth herein. SELLER'S ACCEPTANCE OF THIS ORDER IS EXPRESSLY CONDITIONED ON BUYER'S ASSENT TO THE TERMS CONTAINED HEREIN. The terms and conditions of Seller's proposal (if any) and acknowledgement shall prevail over any conflicting or different terms in Buyer's order unless Buyer notifies Seller in writing of its objections thereto within fifteen (15) days from receipt of Seller's acknowledgement. Buyer's standard terms of purchase will not be considered a counteroffer to Seller's terms and conditions of sale. The failure of Seller to object to any provision in conflict herewith which contained on Buyer's purchase order or otherwise shall not be construed as a waiver of the provisions hereof nor as an acceptance thereof.

2. QUOTATIONS AND PRICES:

Any product, service capability or manufacturing capability which may be available at the time a quotation is made is subject to prior sale. Prices quoted are subject to change without notice. The price in effect at the time of shipment including any escalation formula will apply, unless a valid quotation or written agreement to the contrary exists between Buyer and Seller. All prices shown are in U.S. dollars and are F.O.B. Seller's shipping point. Seller reserves the right to place a service charge on past due accounts at the highest rate permitted by law. Any documentation pertaining to traceability requirements for raw materials or products or documentation required for any routine or special processes must be identified by the Buyer at the time of quotation (if any) or at the time of order placement.

3. TAXES:

Any tax or other charge imposed by law on the sale or production of goods or the performance of services shall be paid by the Buyer, unless the law specifically provides that such payment must be made by Seller, in which case Buyer shall reimburse Seller for such payment as part of the purchase price. Custom duties, consular fees, insurance charges and other comparable charges will be borne by Buyer.

4. SHIPPING SCHEDULE AND DELIVERY:

Shipment schedules are given as accurately as conditions permit and every effort will be made to make shipments as scheduled. Seller will not be responsible for deviations in meeting shipping schedules nor for any losses or damages to Buyer (or any third party) occasioned by deviations in the shipping schedule, whether due to Acts of God, orders bearing priority ratings established pursuant to law, differences with workmen, local labor shortages, fire, flood, shortages or failure of raw materials, supplies, fuel, power or transportation, breakdown of equipment or any other causes beyond Seller's reasonable control, whether of similar or dissimilar nature than those enumerated. Seller shall have additional time within which to perform as may be reasonably necessary under the circumstances and shall have the right to apportion its production among its customers in such a manner as it may consider to be equitable. Seller reserves the right to furnish commercially equivalent or better substitutes for materials or to subcontract the Buyer's order or portions thereof as Seller deems necessary. In no event shall Seller be liable for any consequential damages resulting from failure or delay in shipment. If Buyer requires drawings, procedures, standards or similar material for approval, shipping schedules will be calculated from the time such approvals are received by Seller, since shipping schedules are based on Seller having all required information and a firm order from Buyer which is enterable into production. Any hold points, witness points or the need for inspection by Buyer's representatives must be identified by Buyer at the time of quotation (if any) and/or order placement in order that the effect on the prices or shipping schedules (if any) can be taken into account. Additional inspection or testing required by Buyer which affects normal production sequence will be considered as extending the shipping dates accordingly.

5. TERMS OF PAYMENT:

Terms of payment are 30 days from date of invoice unless otherwise stated in the quotation or Seller's order acknowledgment.

6. CANCELLATIONS AND RETURNS:

Purchase orders once placed by Buyer and accepted by Seller can be canceled only with Seller's written consent and upon terms which will save Seller from loss. No products may be returned for credit or adjustment without written permission from Seller's office authorized to issue such permission.

7. WARRANTIES:

All products of Seller's manufacture except for its Orbit product are warranted against defects of material and workmanship for a period of twelve (12) months from the date of installation or eighteen (18) months from date of shipment, whichever period first expires while its Orbit product is warranted for thirty six (36) months from date of shipment, when all such products are used in the service and within the pressure range for which they were manufactured. In the case of products or parts not wholly of Seller's manufacture, Seller's liability shall be limited to the extent of its recovery from the manufacturer of such products or parts under its liability to Seller. Any repair work performed by Seller is warranted for one year from completion of such repairs and applies only to work performed. If, within these specified periods, Seller receives notice from Buyer of any alleged defect in or nonconformance of any product or repair and if in the Seller's sole judgment the product or repair does not conform or is found to be defective in material or workmanship, then, Buyer shall, at Seller's request, return the part or product F.O.B. to Seller's designated plant or service location. Seller has no liability for removal or reinstallation of products or equipment. Seller, at its option and expense, shall repair or replace the defective part or product, or repair to Buyer the full price paid by Buyer for such defective part, repair or product. Any repayment of purchase price shall be without interest. Seller's warranty liability, including defects caused by Seller's negligence, shall be limited to such repair, replacement or refund, and shall not include claims for labor costs, expenses of Buyer resulting from such defects, recovery under general tort law or strict liability or for damages resulting from delays, loss of use, or other direct, indirect, incidental or consequential damages of any kind. Seller will not be responsible for failures of products which have been in any way tampered with or altered by anyone other than an authorized representative of Seller, failures due to lack of compliance with recommended maintenance procedures or products which have been repaired or altered in such a way (in Seller's judgment) as to affect the products adversely. THIS WARRANTY IS EXPRESSLY IN LIEU OF ALL OTHER WARRANTIES, EXPRESS, STATUTORY OR IMPLIED, INCLUDING THE WARRANTY OF MERCHANTABILITY AND FITNESS FOR PARTICULAR PURPOSE WHICH EXCEED THE FOREGOING WARRANTY.

8. ENGINEERING AND SERVICE:

Upon request, Seller will provide engineering and/or technical information regarding its products and their uses and, if feasible, will provide personnel to assist Buyer in effecting field installations and/or field service. Any such information, service or assistance so provided, whether with or without charge, shall be advisory only.

9. LABOR STANDARDS:

Seller hereby certifies that these products were produced in accordance with all applicable requirements of Section 6, 7 and 12 of the Fair Labor Standards Act as amended and of regulations and orders of the United States Department of Labor issued under Section 14 thereof.

10. INSPECTION:

Unless otherwise agreed in writing, final inspection and acceptance of products must be made at Seller's plant or other shipping or receiving point designated by Seller and shall be conclusive except as regards latent defects. Buyer's representatives may inspect at the Seller's plant or shipping point during working hours prior to shipment in such manner as will not interfere with operations.

11. DELIVERY AND ACCEPTANCE:

Delivery shall be in accordance with the requirements in the Purchase Contract, provided, in the event Buyer is unable to accept delivery upon completion of the manufacture of the Goods in accordance with such requirements, Buyer agrees that (i) title and risk of ownership shall pass to Buyer on date of Seller's invoice, and (ii) Buyer will make payments within thirty days after date of such invoice. Seller shall retain custodial risk of loss until delivery is made in accordance with such requirements.

12. EXPORT COMPLIANCE:

The Buyer shall provide the Seller with relevant end-use, end-user and country of end-use information with respect to the goods, services, software or technology to be supplied hereunder (collectively, "Items"). Based on and in reliance on such information, the Seller will supply such Items in compliance with applicable trade and customs laws including that of the United States of America. The Seller cautions and the Buyer acknowledges that any change in end-use, end-user or country of end-use (including a shipment between countries other than the U.S.) may be restricted or prohibited by applicable trade and

customs law, whether it be of the U.S. or other country. The Parties shall comply with all trade and customs laws (including U.S. Export Controls) except for any such laws which conflict with or are otherwise penalized under the laws of the U.S., which in the event of such conflict, Seller shall notify Buyer. The Buyer agrees in particular that it shall not use and shall not permit any third party to use such items in connection with the design, production, use, or storage of chemical, biological or nuclear weapons or missiles of any kind.

13. TRANSPORTATION CHARGES, ALLOWANCES, CLAIMS:

All prices are F.O.B. Seller's plant or other designated shipping point. No freight is allowed unless stated in Seller's quotation (if any) or in a written contract which may exist between Seller and Buyer at the time of shipment. If Seller's quotation or a written contract states that all or a portion of freight is allowed, all prices are F.O.B. Seller's plant or other designated shipping point, with most economical surface transportation allowed. If the quoted or contractual price includes transportation, Seller reserves the right to designate the common carrier and to ship in the manner it deems most economical. Added costs due to special routing requested by the Buyer are chargeable to the Buyer. Under no circumstances is any freight allowance which is absorbed by Seller to be deducted from the selling price. If the quoted price or contract includes transportation, no deduction will be made in lieu thereof whether Buyer accepts shipment at plant, warehouse, freight station, or otherwise supplies its own transportation. When sales are made from the Seller's warehouse, Seller reserves the right to charge either actual or pro-rated freight from Seller's principle point of manufacture to Seller's warehouse. Buyer assumes risk of loss upon delivery to the carrier, regardless of who pays shipping costs. Seller endeavors to pack or prepare all shipments so that they will not break, rust or deteriorate in transit, but does not guarantee against such damage. Unless requested in writing by the Buyer, no shipments are insured by Seller against damage or loss in transit. Seller will place insurance as nearly as possible in accordance with Buyer's written instructions but in such case Seller acts only as agent between the insurance company and the Buyer and assumes no liability whatsoever. Any claims for shipping loss, breakage or damage (obvious or concealed) are Buyer's responsibility and should be made to the carrier. All claims regarding shortages must be made within thirty (30) days from receipt of shipment and must be accompanied by the packing list(s) covering the shipment.

14. INDEMNIFICATION AND LIMITATION OF LIABILITY:

A. INDEMNIFICATION:

"Buyer Group" means: Buyer, its parent (if any), subsidiaries, affiliates, co-owners, co-venturers, partners and any entity with whom Buyer has an economic interest with respect to the Work including Buyer's customer and its and their respective employees, personnel, directors, officers, borrowed servants, representatives, agents, contractors and subcontractors (respectively and of any tier or level and who are not included within the Seller Group). "Seller Group" means: Seller, its parent (if any), subsidiaries, affiliates, co-owners and its and their respective employees, personnel, directors, officers, borrowed servants, representatives, agents, contractors and subcontractors (respectively and of any tier or level and who are not included within the Buyer Group). "Negligence" means: sole, joint or concurrent, active, passive, gross or willful misconduct.

(1) Seller shall release, defend, save, indemnify (collectively "Indemnify") and hold Buyer Group harmless from and against all claims, demands, losses, damages and causes of action of whatever kind or nature (collectively "Claims"), for loss of or damage to the property of the members of the Seller Group even if such Claims arise from or attributable to the Negligence of the members of Buyer Group.

(2) Seller shall Indemnify and hold Buyer Group harmless from and against all Claims for the death(s) of or personal injury(ies) to members of the Seller Group even if such Claims arise from or attributable to the Negligence of the members of Buyer Group.

(3) Buyer shall Indemnify and hold Seller Group harmless from and against all Claims for loss of or damage to the property (including the Work) of the members of the Buyer Group even if such Claims arise from or attributable to the Negligence of the members of Seller Group.

(4) Buyer shall Indemnify and hold Seller Group harmless from and against all Claims for the death(s) of or personal injury(ies) to members of the Buyer Group even if such Claims arise from or attributable to the Negligence of the members of Seller Group.

(5) Buyer (on its own behalf and on behalf of Buyer Group) and Seller (on its own behalf and on behalf of Seller Group) shall Indemnify and hold each other harmless from and against any and all Claims asserted against them by or on behalf of any third party for the death(s) of or personal injury (ies) to such a third party, as well as loss (es) of or damage(s) to the property of such a third party. A third party is a person or entity not included in Buyer Group or Seller Group. It is agreed by Buyer and Seller that their respective duty of indemnity to each other with respect to Claims asserted against them by a third party pursuant to this Article 14 (A) (5) shall be limited to their respective degree of Negligence.

(6) Notwithstanding any other provision contained in this Agreement, Buyer shall Indemnify and hold the members of Seller Group harmless from and against all Claims (including clean-up costs and loss (es) of oil, gas or hydrocarbons) arising from pollution, contamination, dumping or spilling of any substance and even if arising out of or attributable to the Negligence of the members of the Seller Group.

B. INDEMNITY FOR CONSEQUENTIAL DAMAGES:

UNDER NO CIRCUMSTANCES SHALL SELLER BE LIABLE FOR ANY SPECIAL, CONSEQUENTIAL, INCIDENTAL, EXEMPLARY OR PUNITIVE DAMAGES (collectively "CONSEQUENTIAL"), AS DEFINED BY THE LAWS GOVERNING THIS PURCHASE ORDER, NOR FOR ANY LOSS OF ANTICIPATED PROFITS, LOSS OF BUSINESS OPPORTUNITY, LOSS OF USE OF EQUIPMENT OR OF ANY INSTALLATION, SYSTEM OR FACILITY INTO WHICH SELLER'S EQUIPMENT MAY BE LOCATED OR AT WHICH MEMBERS OF THE SELLER GROUP MAY BE PERFORMING WORK AND BUYER AGREES TO "INDEMNIFY" AND HOLD SELLER GROUP HARMLESS FROM AND AGAINST ANY "CLAIMS" FOR SUCH "CONSEQUENTIAL" DAMAGES EVEN IF ARISING OUT OF OR ATTRIBUTABLE TO THE "NEGLIGENCE" OF THE MEMBERS OF THE SELLER GROUP.

C. LIMITATION OF LIABILITY:

EXCEPT AS OTHERWISE EXPRESSLY LIMITED IN THIS AGREEMENT IT IS THE EXPRESS INTENTION OF THE PARTIES HERETO THAT ALL INDEMNITY OBLIGATIONS AND/OR LIABILITIES HEREBY ASSUMED BY THE PARTIES SHALL BE: (i) SUPPORTED BY INSURANCE; (ii) WITHOUT LIMIT; (iii) AND WITHOUT REGARD TO THE CAUSE OR CAUSES THEREOF, INCLUDING, BUT NOT LIMITED TO, PREEXISTING CONDITIONS (WHETHER SUCH CONDITIONS BE PATENT OR LATENT); THE UNSEAWORTHINESS OF ANY VESSEL OR VESSELS (WHETHER OR NOT PREEXISTING); THE UNAIRWORTHINESS OF ANY AIRCRAFT; BREACH OF REPRESENTATION OR WARRANTY (EXPRESS OR IMPLIED); BREACH OF CONTRACT; BREACH OF DUTY (STATUTORY, CONTRACTUAL, COMMON LAW OR OTHERWISE); STRICT LIABILITY; CONDITION OF RUIN OR DEFECTIVE PREMISES, EQUIPMENT, FACILITIES, OR APPURTENANCES OF ANY PARTY UNDER ANY CODE, LAW OR (WHETHER OR NOT SAID CONDITION IS PREEXISTING AND/OR LATENT, PATENT OR OTHERWISE); THE LOADING OR UNLOADING OF PERSONS OR CARGO; TORT; OR THE NEGLIGENCE OR FAULT OF ANY PARTY (AS DEFINED AT THE BEGINNING OF THIS ARTICLE 14; OR ANY OTHER THEORY OF LEGAL LIABILITY).

Seller's total responsibility for any claims, damages, losses or liability arising out of or related to its performance of this contract or the products or services covered hereunder shall not exceed the purchase price.

15. MODIFICATION, RESCISSION & WAIVER:

The terms herein may not be modified or rescinded nor any of its provisions waived unless such modification, rescission or waiver is in writing and signed by an authorized employee of Seller at its office in Houston, Texas. Failure of Seller to insist in any one or more instances upon the performance of any of the terms and conditions of the contract or the failure of Seller to exercise any of its rights hereunder shall not be construed as a waiver or relinquishment of any such term, condition, or right hereunder and shall not affect Seller's right to insist upon strict performance and compliance with regard to any unexecuted portions of this contract or future performance of these terms and conditions.

All orders must be accepted by an authorized employee of Seller. The rights and duties of the parties and construction and effect of all provisions hereof shall be governed by and construed according to the internal laws of the State of Texas. Any disputes which arise under this agreement shall be venued in the District Court of Harris County, Texas or in the Southern District of Texas.

**VALVES & MEASUREMENT**

3250 Briarpark Drive, Suite 300
Houston, Texas 77042
USA Toll Free 800 323 9160

For the most current contact and location information go to: www.c-a-m.com/valvesandmeasurement